

TL500I, TL500C, TL501I, TL501C, TL502C, TL503C ANALOG-TO-DIGITAL CONVERTER BUILDING BLOCKS

D2477 DECEMBER 1979—REVISED JANUARY 1989

TL500I, TL500C, TL501I, TL501C ANALOG PROCESSORS

- True Differential Inputs
- Automatic Zero
- Automatic Polarity
- High Input Impedance . . . 10^9 Ohms
Typically

TL500I, TL500C CAPABILITIES

- Resolution . . . 14 Bits (with TL502C)
- Linearity Error . . . 0.001%
- 4 1/2-Digit Readout Accuracy with External Precision Reference

TL502C/TL503C DIGITAL PROCESSORS

- Fast Display Scan Rates
- Internal Oscillator May Be Driven or Free-Running
- Interdigit Blanking
- Over-Range Blanking
- 4 1/2-Digit Display Circuitry
- High-Sink-Current Digit Driver for Large Displays

TL501I, TL501C CAPABILITIES

- Resolution . . . 10-13 Bits (with TL502C)
- Linearity Error . . . 0.01%
- 3 1/2-Digit Readout Accuracy

TL502C CAPABILITIES

- Compatible with Popular Seven-Segment Common-Anode Displays
- High-Sink-Current Segment Driver for Large Displays

TL503C CAPABILITIES

- Multiplexed BCD Outputs
- High-Sink-Current BCD Outputs



Caution. These devices have limited built-in gate protection. The leads should be shorted together or the device placed in conductive foam during storage or handling to prevent electrostatic damage to the MOS gates.

description

The TL500I, TL500C, TL501I, and TL501C analog processors and TL502C and TL503C digital processors provide the basic functions for a dual-slope-integrating analog-to-digital converter.

The TL500 and TL501 contain the necessary analog switches and decoding circuits, reference voltage generator, buffer, integrator, and comparator. These devices may be controlled by the TL502C, TL503C, by discrete logic, or by a software routine in a microprocessor.

The TL502C and TL503C each includes oscillator, counter, control logic, and digit enable circuits. The TL502C provides multiplexed outputs for seven-segment displays, while the TL503C has multiplexed BCD outputs.

When used in complementary fashion, these devices form a system that features automatic zero-offset compensation, true differential inputs, high input impedance, and capability for 4 1/2-digit accuracy. Applications include the conversion of analog data from high-impedance sensors of pressure, temperature, light, moisture, and position. Analog-to-digital logic conversion provides display and control signals for weight scales, industrial controllers, thermometers, light-level indicators, and many other applications.

PRODUCTION DATA documents contain information current as of publication date. Products conform to specifications per the terms of Texas Instruments standard warranty. Production processing does not necessarily include testing of all parameters.

**TEXAS
INSTRUMENTS**

Copyright © 1979, Texas Instruments Incorporated

POST OFFICE BOX 655303 • DALLAS, TEXAS 75265

2-77

TL500I, TL500C, TL501I, TL501C, TL502C, TL503C ANALOG-TO-DIGITAL-CONVERTER BUILDING BLOCKS

principles of operation

The basic principle of dual-slope-integrating converters is relatively simple. A capacitor, C_X , is charged through the integrator from V_{CT} for a fixed period of time at a rate determined by the value of the unknown voltage input. Then the capacitor is discharged at a fixed rate (determined by the reference voltage) back to V_{CT} where the discharge time is measured precisely. The relationship of the charge and discharge values are shown below (see Figure 1).

$$V_{CX} = V_{CT} - \frac{V_I t_1}{R_X C_X} \quad \text{Charge} \quad (1)$$

$$V_{CT} = V_{CX} - \frac{V_{ref} t_2}{R_X C_X} \quad \text{Discharge} \quad (2)$$

Combining equations 1 and 2 results in:

$$\frac{V_I}{V_{ref}} = \frac{t_2}{t_1} \quad (3)$$

where:

- V_{CT} = Comparator (offset) threshold voltage
- V_{CX} = Voltage change across C_X during t_1 and during t_2 (equal in magnitude)
- V_I = Average value of input voltage during t_1
- t_1 = Time period over which unknown voltage is integrated
- t_2 = Unknown time period over which a known reference voltage is integrated.

Equation (3) illustrates the major advantages of a dual-slope converter:

- a. Accuracy is not dependent on absolute values of t_1 and t_2 , but is dependent on their ratios. Long-term clock frequency variations will not affect the accuracy.
- b. Offset values, V_{CT} , are not important.

The BCD counter in the digital processor (see Figure 2) and the control logic divide each measurement cycle into three phases. The BCD counter changes at a rate equal to one-half the oscillator frequency.

auto-zero phase

The cycle begins at the end of the integrate-reference phase when the digital processor applies low levels to inputs A and B of the analog processor. If the trigger input is at a high level, a free-running condition exists and continuous conversions are made. However, if the trigger input is low, the digital processor stops the counter at 20,000, entering a hold mode. In this mode, the processor samples the trigger input every 4000 oscillator pulses until a high level is detected. When this occurs, the counter is started again and is carried to completion at 30,000. The reference voltage is stored on reference capacitor C_{ref} , comparator offset voltage is stored on integration capacitor C_X , and the sum of the buffer and integrator offset voltages is stored on zero capacitor C_Z . During the auto-zero phase, the comparator output is characterized by an oscillation (limit cycle) of indeterminate waveform and frequency that is filtered and d-c shifted by the level shifter.

integrate-input phase

The auto-zero phase is completed at a BCD count of 30,000, and high levels are applied to both control inputs to initiate the integrate-input phase. The integrator charges C_X for a fixed time of 10,000 BCD counts at a rate determined by the input voltage. Note that during this phase, the analog inputs see only the high impedance of the noninverting operational amplifier input. Therefore, the integrator responds only to the difference between the analog input terminals, thus providing true differential inputs.

integrate-reference phase

At a BCD count of $39,999 + 1 = 40,000$ or 0, the integrate-input phase is terminated and the integrate-reference phase is begun by sampling the comparator output. If the comparator output is low corresponding to a negative average analog input voltage, the digital processor applies a low and a high to inputs A and B, respectively, to apply the reference voltage stored on C_{ref} to the buffer. If the comparator output is high corresponding to a positive input, inputs A and B are made high and low, respectively, and the negative of the stored reference voltage is applied to the buffer. In either case, the processor automatically selects the proper logic state to cause the integrator to ramp back toward zero at a rate proportional to the reference voltage. The time required to return to zero is measured by the counter in the digital processor. The phase is terminated when the integrator output crosses zero and the counter contents are transferred to the register, or when the BCD counter reaches 20,000 and the over-range indication is activated. When activated, the over-range indication blanks all but the most significant digit and sign.

Seventeen parallel bits (4-1/2 digits) of information are strobed into the buffer register at the end of the integration phase. Information for each digit is multiplexed out to the BCD outputs (TL503C) or the seven-segment drivers (TL502C) at a rate equal to the oscillator frequency divided by 200.

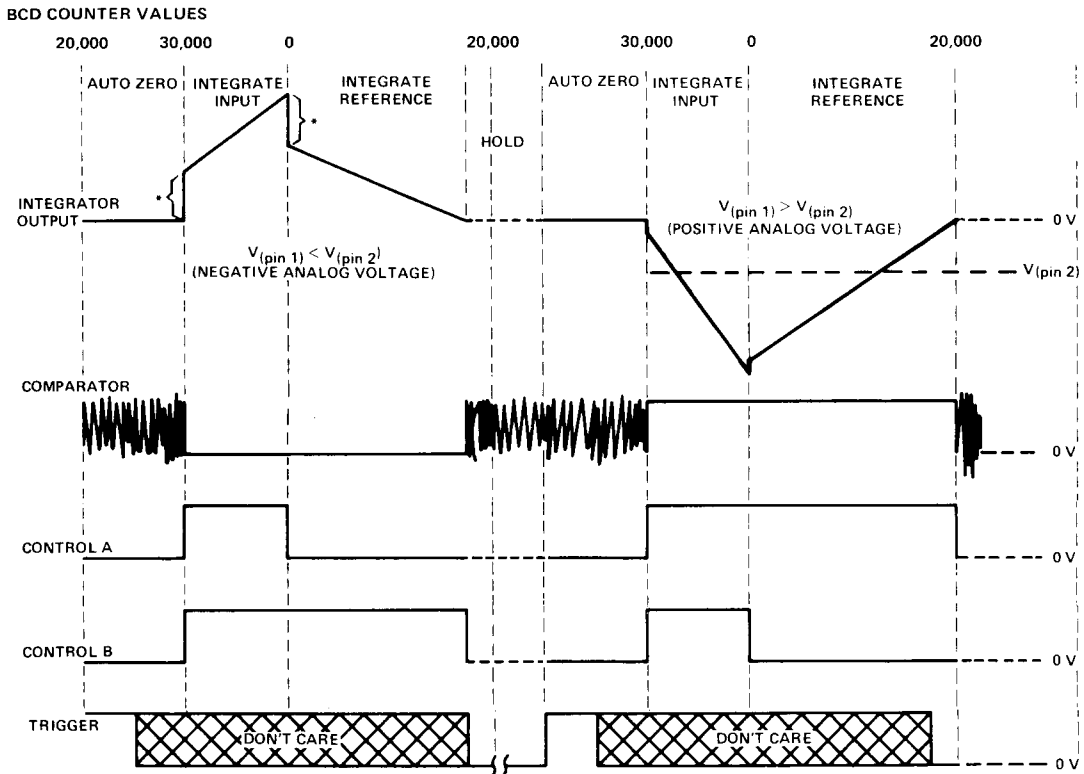

*This step is the voltage at pin 2 with respect to analog ground.

FIGURE 1. VOLTAGE WAVEFORMS AND TIMING DIAGRAM

TL500, TL501, TL502C, TL503C ANALOG-TO-DIGITAL-CONVERTER BUILDING BLOCKS

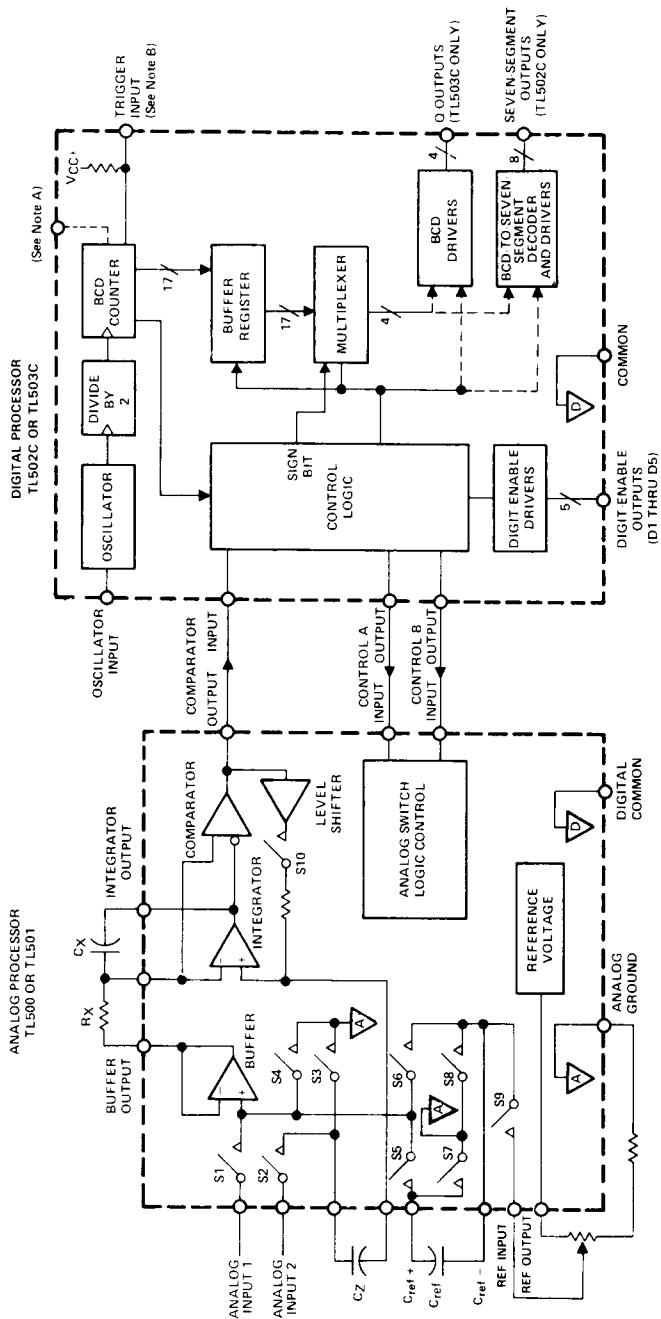

NOTES: A. Pin 18 of the TL502C provides an output of f_{osc} (oscillator frequency) \rightarrow 20,000.
 B. The trigger input assumes a high level if not externally connected.

FIGURE 2. BLOCK DIAGRAM OF BASIC ANALOG-TO-DIGITAL CONVERTER USING TL500 OR TL501 AND TL502C OR TL503C

MODE	ANALOG INPUT	COMPARATOR	CONTROLS A AND B	ANALOG SWITCHES
Auto Zero	X	Oscillation	L L	S3, S4, S7, S9, S10
Hold†				
Integrate	Positive	H	H H	S1, S2
	Negative	L		
Integrate		L‡	L H	S3, S6, S7
		H‡	H L	S3, S5, S8
Reference	X			

H = High, L = low, X = Irrelevant

† If the trigger input is low at the beginning of the auto-zero cycle, the system will enter the hold mode. A high level (or open circuit) will signal the digital processor to continue or resume normal operation.

‡ This is the state of the comparator output as determined by the polarity of the analog input during the integrate input phase.

TL500I, TL500C, TL501I, TL501C ANALOG PROCESSORS

description of analog processors

The TL500 and TL501 analog processors are designed to automatically compensate for internal zero offsets, integrate a differential voltage at the analog inputs, integrate a voltage at the reference input in the opposite direction, and provide an indication of zero-voltage crossing. The external control mechanism may be a microcomputer and software routing, discrete logic, or a TL502C or TL503C controller. The TL500 and TL501 are designed primarily for simple, cost-effective, dual-slope analog-to-digital converters. Both devices feature true differential analog inputs, high input impedance, and an internal reference-voltage source. The TL500 provides 4-1/2-digit readout accuracy when used with a precision external reference voltage. The TL501 provides 100-ppm linearity error and 3-1/2-digit accuracy capability. These devices are manufactured using TI's advanced technology to produce JFET, MOSFET, and bipolar devices on the same chip. The TL500C and TL501C are characterized for operation over the temperature range of 0°C to 70°C. The TL500I and TL501I are characterized for operation from -40°C to 85°C.

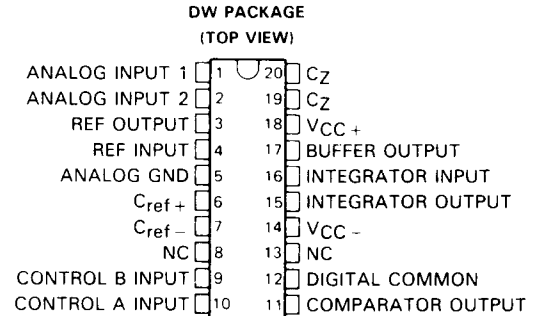
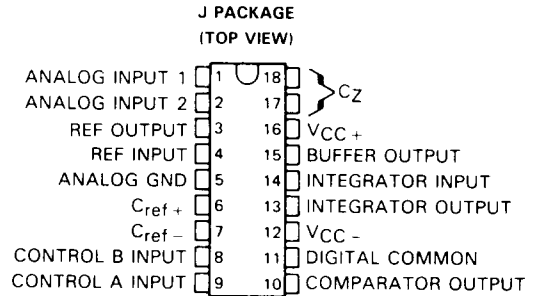

NC: No internal connection

AVAILABLE OPTIONS

T _A	LINEARITY ERROR	PACKAGE	
		CERAMIC DIP (J)	WIDE-BODY SO (DW)
0°C to 70°C	0.005% FS	TL500CJ	TL500CDW
	0.05% FS	TL501CJ	TL501CDW
-40°C to 85°C	0.005% FS	TL500IJ	TL500IDW
	0.05% FS	TL501IJ	TL501IDW

TL500I, TL500C, TL501I, TL501C ANALOG PROCESSORS

schematics of inputs and outputs

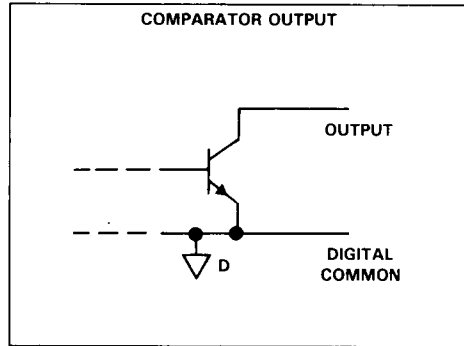
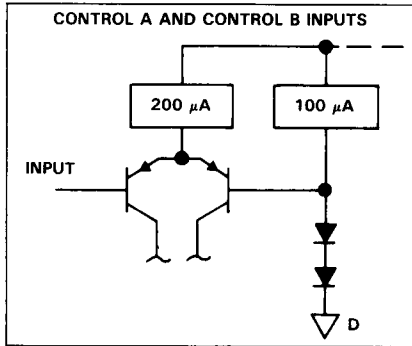

absolute maximum ratings over operating free-air temperature range (unless otherwise noted)

Positive supply voltage, V_{CC+} (see Note 1)	+18 V
Negative supply voltage, V_{CC-}	-18 V
Input voltage, V_I	$\pm V_{CC}$
Comparator output voltage range (see Note 2)	0 V to V_{CC+}
Comparator output sink current (see Note 2)	20 mA
Buffer, reference, or integrator output source current (see Note 2)	10 mA
Total dissipation	See Dissipation Rating Table
Operating free-air temperature range: TL500I, TL501I	-40 to 85°C
TL500C, TL501C	0°C to 70°C
Storage temperature range	-65°C to 150°C
Lead temperature 1,6 mm (1/16 inch) from case for 10 seconds: DW package	260°C
Lead temperature 1,6 mm (1/16 inch) from case for 60 seconds: J package	300°C

- NOTES: 1. Voltage values, except differential voltages, are with respect to the analog ground common pin tied together.
2. Buffer, integrator, and comparator outputs are not short-circuit protected.

DISSIPATION RATING TABLE

PACKAGE	$T_A \leq 25^\circ\text{C}$ POWER RATING	DERATING FACTOR ABOVE $T_A = 25^\circ\text{C}$	$T_A = 70^\circ\text{C}$ POWER RATING	$T_A = 85^\circ\text{C}$ POWER RATING
DW	1125 mW	9 mW/°C	720 mW	585 mW
J	1025 mW	8.2 mW/°C	656 mW	533 mW

recommended operating conditions

		MIN	NOM	MAX	UNIT
Positive supply voltage, V_{CC+}		7	12	15	V
Negative supply voltage, V_{CC-}		-9	-12	-15	V
Reference input voltage, $V_{ref(I)}$		0.1		5	V
Analog input voltage, V_I				± 5	V
Differential analog input voltage, V_{ID}				10	V
High-level input voltage, V_{IH}	Control inputs	2			V
Low-level input voltage, V_{IL}	Control inputs			0.8	V
Peak positive integrator output voltage, V_{OM+}		+9			V
Peak negative integrator output voltage, V_{OM-}		-5			V
Full scale input voltage				$2 V_{ref}$	
Autozero and reference capacitors, C_Z and C_{ref}		0.2			μF
Integrator capacitor, C_X		0.2			μF
Integrator resistor, R_X		15		100	k Ω
Integrator time constant, $R_X C_X$		See Note 3			
Free-air operating temperature, T_A	TL500I, TL501I	-40		85	$^{\circ}C$
	TL500C, TL501C	0		70	
Maximum conversion rate with TL502C or TL503C			3	12.5	conv/sec

system electrical characteristics at $V_{CC\pm} = \pm 12 V$, $V_{ref} = 1,000 \pm 0.03 mV$, $T_A = 25^{\circ}C$ (unless otherwise noted) (see Figure 3)

PARAMETER	TEST CONDITIONS	TL501			TL500			UNIT
		MIN	TYP	MAX	MIN	TYP	MAX	
Zero error			50	300		10	30	μV
Linearity error relative to full scale	$V_I = 2 V$ to $2 V$		0.005	0.05		0.001	0.005	%FS
Full scale temperature coefficient	$T_A =$ full range		6			6		ppm/ $^{\circ}C$
Temperature coefficient of zero error			4			1		$\mu V/^{\circ}C$
Rollover error [†]			200	500		30	100	μV
Equivalent peak-to-peak input noise voltage			20			20		μV
Analog input resistance	Pin 1 or 2		10^9			10^9		Ω
Common-mode rejection ratio	$V_{IC} = -1 V$ to $+1 V$		86			90		dB
Current into analog input	$V_I = \pm 5 V$		50			50		pA
Supply voltage rejection ratio			90			90		dB

[†]Rollover error is the voltage difference between the conversion results of the full-scale positive 2 V and the full-scale negative 2 V. NOTE 3. The minimum integrator time constant may be found by use of the following formula:

$$\text{Minimum } R_X C_X = \frac{V_{ID} (\text{full scale}) t_1}{|V_{OM-}| - V_I(\text{pin 2})}$$

where

V_{ID} = voltage at pin with respect to pin 2

$V_I(\text{pin 2})$ = voltage at pin 2 with respect to analog ground

t_1 = input integration time seconds

TL500I, TL500C, TL501I, TL501C

ANALOG PROCESSORS

electrical characteristics at $V_{CC\pm} = \pm 12\text{ V}$, $V_{ref} = 1\text{ V}$, $T_A = 25^\circ\text{C}$ (see Figure 3)

integrator and buffer operational amplifiers

PARAMETER	TEST CONDITIONS	MIN	TYP	MAX	UNIT
V_{IO} Input offset voltage			15		mV
I_{IB} Input bias current			50		pA
V_{OM+} Positive output voltage swing		9	11		V
V_{OM-} Negative output voltage swing		-5	-7		V
A_{VD} Voltage amplification			110		dB
B_1 Unity-gain bandwidth			3		MHz
CMRR Common mode rejection	$V_{IC} = -1\text{ V to } +1\text{ V}$		100		dB
SR Output slew rate			5		V/ μs

comparator

PARAMETER	TEST CONDITIONS	MIN	TYP	MAX	UNIT
V_{IO} Input offset voltage			15		mV
I_{IB} Input bias current			50		pA
A_{VD} Voltage amplification			100		dB
V_{OL} Low-level output voltage	$I_{OL} = 1.6\text{ mA}$		200	400	mV
I_{OH} High-level output current	$V_{OH} = 3\text{ V}$		5	20	nA

voltage reference output

PARAMETER	TEST CONDITIONS	MIN	TYP	MAX	UNIT
$V_{ref(0)}$ Reference voltage		1.12	1.22	1.32	V
αV_{ref} Reference-voltage temperature coefficient	$T_A = \text{full range}$		80		ppm/ $^\circ\text{C}$
r_o Reference output resistance			3		Ω

logic control section

PARAMETER	TEST CONDITIONS	MIN	TYP	MAX	UNIT
I_{IH} High-level input current	$V_{IH} = 2\text{ V}$		1	10	μA
I_{IL} Low-level input current	$V_{IL} = 0.8\text{ V}$		-40	-300	μA

total device

PARAMETER	TEST CONDITIONS	MIN	TYP	MAX	UNIT
I_{CC+} Positive supply current			15	20	mA
I_{CC-} Negative supply current			12	18	mA

PARAMETER MEASUREMENT INFORMATION

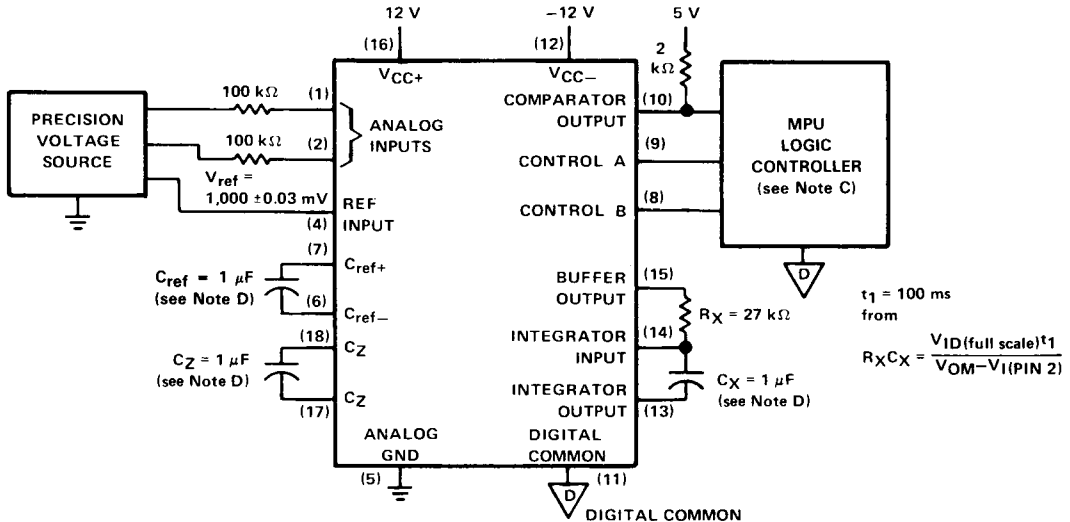

NOTES: C. Tests are started approximately 5 seconds after power-on.
D. Capacitors used are TRW's X363UW polypropylene or equivalent for C_X , C_{ref} , and C_Z ; however for C_{ref} and C_Z film-dielectric capacitors may be substituted.

FIGURE 3. TEST CIRCUIT CONFIGURATION

external-component selection guide

The autozero capacitor C_Z and reference capacitor C_{ref} should be within the recommended range of operating conditions and should have low-leakage characteristics. Most film-dielectric capacitors and some tantalum capacitors provide acceptable results. Ceramic and aluminum capacitors are not recommended because of their relatively high-leakage characteristics.

The integrator capacitor C_X should also be within the recommended range and must have good voltage linearity and low dielectric absorption. A polypropylene-dielectric capacitor similar to TRW's X363UW is recommended for 4-1/2-digit accuracy. For 3-1/2-digit applications, polyester, polycarbonate, and other film dielectrics are usually suitable. Ceramic and electrolytic capacitors are not recommended.

Stray coupling from the comparator output to any analog pin (in order of importance 17, 18, 14, 7, 6, 13, 1, 2, 15) must be minimized to avoid oscillations. In addition, all power supply pins should be bypassed at the package, for example, by a 0.01- μ F ceramic capacitor.

Analog and digital common are internally isolated and may be at different potentials. Digital common can be within 4 V of positive or negative supply with the logic decode still functioning properly.

The time constant $R_X C_X$ should be kept as near the minimum value as possible and is given by the formula:

$$\text{Minimum } R_X C_X = \frac{V_{ID}(\text{full scale}) t_1}{|V_{OM} - V_I(\text{pin2})|}$$

where:

$V_{ID}(\text{full scale})$ = Voltage on pin 1 with respect to pin 2

t_1 = Input integration time in seconds

$V_I(\text{pin2})$ = Voltage on pin 2 with respect to analog ground.

TL502C, TL503C DIGITAL PROCESSORS

description of digital processors

The TL502C and TL503C are control logic devices designed to complement the TL500 and TL501 analog processors. They feature interdigit blanking, over-range blanking, an internal oscillator, and a fast display scan rate. The internal-oscillator input is a Schmitt trigger circuit that can be driven by an external clock pulse or provide its own time base with the addition of a capacitor. The typical oscillator frequency is 120 kHz with a 470-pF capacitor connected between the oscillator input and ground.

The TL502C provides seven-segment-display output drivers capable of sinking 100 mA and compatible with popular common-anode displays. The TL503C has four BCD output drivers capable of 100-mA sink currents. The code (see next page and Figure 4) for each digit is multiplexed to the output drivers in phase with a pulse on the appropriate digit-enable line at a digit rate equal to f_{OSC} , divided by 200. Each digit-enable output is capable of sinking 20-mA.

The comparator input of each device, in addition to monitoring the output of the zero-crossing detector in the analog processor, may be used in the display test mode to check for wiring and display faults. A high logic level (2 to 6.5 V) at the trigger input with the comparator input at or below 6.5 V starts the integrate-input phase. Voltage levels equal to or greater than 7.9 V on both the trigger and comparator inputs clear the system and set the BCD counter to 20,000. When normal operation resumes, the conversion cycle is restarted at the auto zero phase.

These devices are manufactured using I²L and bipolar techniques. The TL502C and TL503C are characterized for operation from 0°C to 70°C.

TL502C . . . N PACKAGE
(TOP VIEW)

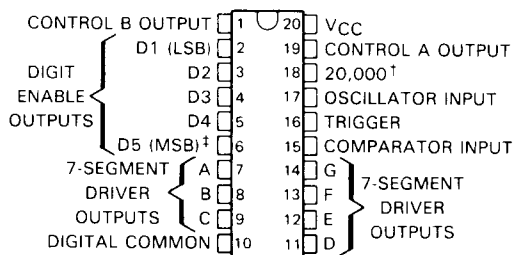

TL503C . . . N PACKAGE
(TOP VIEW)

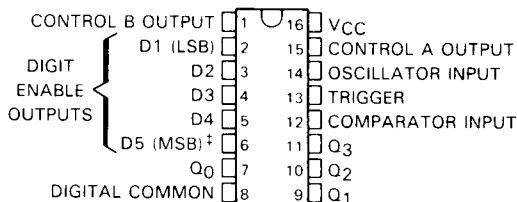

[†]Pin 18 of TL502C provides an output of f_{OSC} (oscillator frequency) = 20,000.

[‡]D5, the most significant bit, is also the sign bit.

TABLE OF SPECIAL FUNCTIONS

$V_{CC} = 5 V \pm 10\%$

TRIGGER INPUT	COMPARATOR INPUT	FUNCTION
$V_I \leq 0.8 V$	$V_I \leq 6.5 V$	Hold at auto-zero cycle after completion of conversion
$2 V \leq V_I \leq 6.5 V$	$V_I \leq 6.5 V$	Normal operation (continuous conversion)
$V_I \leq 6.5 V$	$V_I \geq 7.9 V$	Display Test: All BCD outputs high
$V_I \geq 7.9 V$	$V_I \leq 6.5 V$	Internal Test
Both inputs to go $V_I \geq 7.9 V$ simultaneously		System clear: Sets BCD counter to 20,000. When normal operation is resumed, cycle begins with Auto Zero.

DIGIT 5 (MOST SIGNIFICANT DIGIT) CHARACTER CODES

CHARACTER	TL502C SEVEN-SEGMENT LINES							TL503C BCD OUTPUT LINES			
	A	B	C	D	E	F	G	Q3 8	Q2 4	Q1 2	Q0 1
+	H	H	H	H	L	L	L	H	L	H	L
+1	H	L	L	H	L	L	L	H	H	H	L
-	L	H	H	L	H	H	L	H	L	H	H
-1	L	L	L	L	H	H	L	H	H	H	H

DIGITS 1 THRU 4 NUMERIC CODE (See Figure 4)

NUMBER	TL502C SEVEN-SEGMENT LINES							TL503C BCD OUTPUT LINES			
	A	B	C	D	E	F	G	Q3 8	Q2 4	Q1 2	Q0 1
0	L	L	L	L	L	L	H	L	L	L	L
1	H	L	L	H	H	H	H	L	L	L	H
2	L	L	H	L	L	H	L	L	L	H	L
3	L	L	L	L	H	H	L	L	L	H	H
4	H	L	L	H	H	L	L	L	H	L	L
5	L	H	L	L	H	L	L	L	H	L	H
6	L	H	L	L	L	L	L	L	H	H	L
7	L	L	L	H	H	H	H	L	H	H	H
8	L	L	L	L	L	L	L	H	L	L	L
9	L	L	L	L	H	L	L	H	L	L	H

H = high level, L = low level

schematics of inputs and outputs

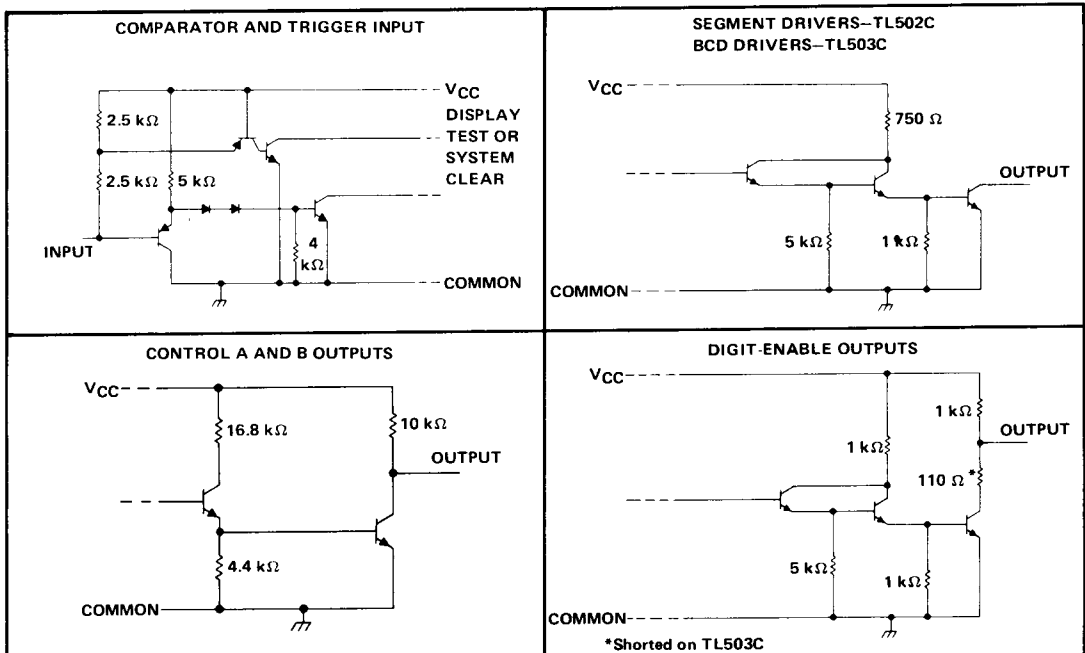

TL502C, TL503C DIGITAL PROCESSORS

absolute maximum ratings

Supply voltage, V_{CC} (see Note 4)		7	V
Input voltage, V_I	Oscillator	5.5	V
	Comparator or Trigger	9	
Output current	BCD or Segment drivers	120	mA
	Digit-enable outputs	40	
	Pin 18 (TL502C only)	20	
Total power dissipation at (or below) 30°C free-air temperature (see Note 5)		1100	mW
Operating free-air temperature range		0 to 70	°C
Storage temperature range		-65 to 150	°C
Lead temperature 1,6 mm (1/16 inch) from case for 10 seconds		260	°C

NOTES: 4. Voltage values are with respect to the network ground terminal.

5. For operation above 30°C free-air temperature, derate linearly to 736 mW at 70°C at the rate of 9.2 mW/°C.

recommended operating conditions

		MIN	NOM	MAX	UNIT
Supply voltage, V_{CC}		4.5	5	5.5	V
High-level input voltage, V_{IH}	Comparator and trigger inputs	2			V
Low-level input voltage, V_{IL}	Comparator and trigger inputs			0.8	V
Operating free-air temperature		0		70	°C

electrical characteristics at 25 °C free-air temperature

PARAMETER	TERMINAL	TEST CONDITIONS	TL502C			TL503C			UNIT	
			MIN	TYP	MAX	MIN	TYP	MAX		
V_{IK}	All inputs	$V_{CC} = 4.5\text{ V}$, $I_I = -12\text{ mA}$	-0.8	-1.5	-0.8	-1.5			V	
V_{T+}	Oscillator	$V_{CC} = 5\text{ V}$		1.5		1.5			V	
V_{T-}	Oscillator	$V_{CC} = 5\text{ V}$		0.9		0.9			V	
$V_{T+} - V_{T-}$	Oscillator	$V_{CC} = 5\text{ V}$	0.4	0.6	0.8	0.4	0.6	0.8		
I_{T+}	Oscillator	$V_{CC} = 5\text{ V}$	-40	-94	-170	-40	-94	-170	μA	
I_{T-}	Oscillator	$V_{CC} = 5\text{ V}$	40	117	170	40	117	170	μA	
V_{OH}	Digit enable	$V_{CC} = 4.5\text{ V}$, $I_{OH} = 0$	4.15	4.4		4.15	4.4		V	
	Pin 18 (TL502C only)		4.25	4.4		4.25	4.4			
	Control A and B		4.25	4.4		4.25	4.4			
V_{OL}	Digit enable	$V_{CC} = 4.5\text{ V}$							V	
	Pin 18 (TL502C only)		$I_{OL} = 20\text{ mA}$							
	Control A and B		$I_{OL} = 10\text{ mA}$	0.15	0.4					
	Segment drivers		$I_{OL} = 2\text{ mA}$	0.088	0.4		0.088	0.4		
	BCD drivers		$I_{OL} = 100\text{ mA}$	0.17	0.3		0.17	0.3		
I_I	Comparator, Trigger	$V_{CC} = 5.5\text{ V}$, $V_I = 5.5\text{ V}$	65	100		65	100		μA	
	Oscillator		1	1		1	1		mA	
I_{IH}	Comparator, Trigger	$V_{CC} = 5.5\text{ V}$, $V_I = 2.4\text{ V}$	-0.6	-1		-0.6	-1		mA	
	Oscillator		0.5	0.5		0.5	0.5			
I_{IL}	Oscillator	$V_{CC} = 5.5\text{ V}$, $V_I = 0.4\text{ V}$	-0.1	-0.17		-0.1	-0.17		mA	
	Comparator, Trigger		-1	-1.6		-1	-1.6			
I_{OH}	Digit enable	$V_{CC} = 4.5\text{ V}$	-2.5	-4		-2.5	-4		mA	
	Pin 18 (TL502C only)		$V_O = 0.5\text{ V}$							
	Control A and B		$V_O = 0.5\text{ V}$	-0.5	-0.9		-0.5	-0.9		
	Segment drivers		$V_O = 0.5\text{ V}$	-0.25	-0.4		-0.25	-0.4		
	BCD drivers		$V_O = 5.5\text{ V}$	0.25	0.25		0.25	0.25		
I_{OL}	Digit enable	$V_{CC} = 4.5\text{ V}$, $V_O = 3.55\text{ V}$	18	23		18	23		mA	
	Supply current		$V_{CC} = 5.5\text{ V}$	73	110	73	110			

TL502C, TL503C DIGITAL PROCESSORS

special functions[†] operating characteristics at 25°C free-air temperature

PARAMETER	TEST CONDITIONS	MIN	TYP	MAX	UNIT
I_I Input current into comparator or trigger inputs	$V_{CC} = 5.5 \text{ V}, V_I = 8.55 \text{ V}$		1.2	1.8	mA
	$V_{CC} = 5.5 \text{ V}, V_I = 6.25 \text{ V}$			0.5	mA

[†]The comparator and trigger inputs may be used in the normal mode or to perform special functions. See the Table of Special Functions.

TYPICAL APPLICATION DATA

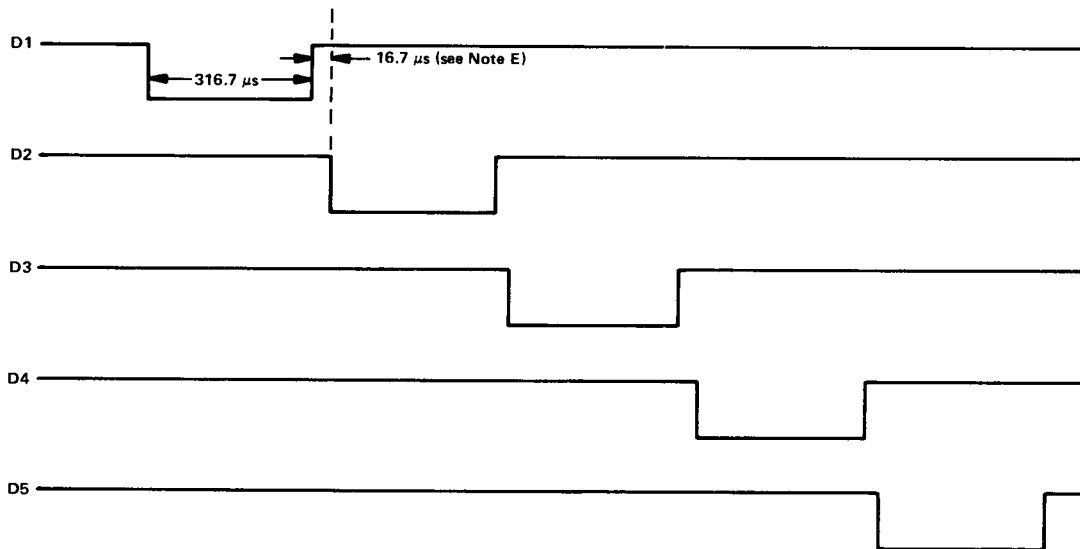

NOTE E: The BCD or seven-segment driver outputs are present for a particular digit slightly before the falling edge of that digit enable.

FIGURE 4. TL502C, TL503C DIGIT TIMING WITH 120-kHz CLOCK SIGNAL AT OSCILLATOR INPUT